

## Power Operational Amplifiers

### FEATURES

- ◆ LOW COST
- ◆ WIDE BANDWIDTH - 1.1 Mhz
- ◆ HIGH OUTPUT CURRENT - 1.5A PER AMPLIFIER
- ◆ WIDE COMMON MODE RANGE Includes negative supply
- ◆ WIDE SUPPLY VOLTAGE RANGE Single supply: 5V to 40V Split supplies:  $\pm 2.5V$  to  $\pm 20V$
- ◆ LOW QUIESCIENT CURRENT
- ◆ VERY LOW DISTORTION

### APPLICATIONS

- ◆ HALF AND FULL BRIDGE MOTOR DRIVERS
- ◆ AUDIO POWER AMPLIFIER
  - Stereo - 11.3W RMS per amplifier
  - Bridge - 22.6W RMS per two amplifiers
  - Two Bridges - 45.2W RMS per package
- ◆ 3 PHASE MOTOR DRIVER
  - 3 Channels - 33.9W RMS per package
- ◆ IDEAL FOR SINGLE SUPPLY SYSTEMS
  - 5V - Peripherals
  - 12V - Automotive
  - 28V - Avionic
- ◆ PACKAGING OPTIONS
  - 20-Pin PSOP, JEDEC MO-166-AB (PA162DK)

### DESCRIPTION

The amplifier design is a dual power op amp on a single monolithic die. The quad output PA162 combines two dual op amp die in a single PSOP package. This approach provides a cost-effective solution to applications where multiple amplifiers are required or a bridge configuration is needed. Four independent amplifiers coupled with low quiescent current and very low THD makes this an ideal low-distortion 4-channel audio amplifier for applications such as laptops and computer speakers.

The quad output PA162DK is available in a surface mount 20-pin PSOP, JEDEC MO-166-AB package. Built-in thermal shutdown allows the devices to self-protect against thermal overloads. Care must be exercised to observe the Safe Operating Area (SOA) curve and proper heatsinking will ensure maximum reliability.

The wide common mode input range includes the negative rail, facilitating single supply applications. This makes it possible to have a ground-based input driving a single supply amplifier with ground acting as the second or bottom supply of the amplifier.

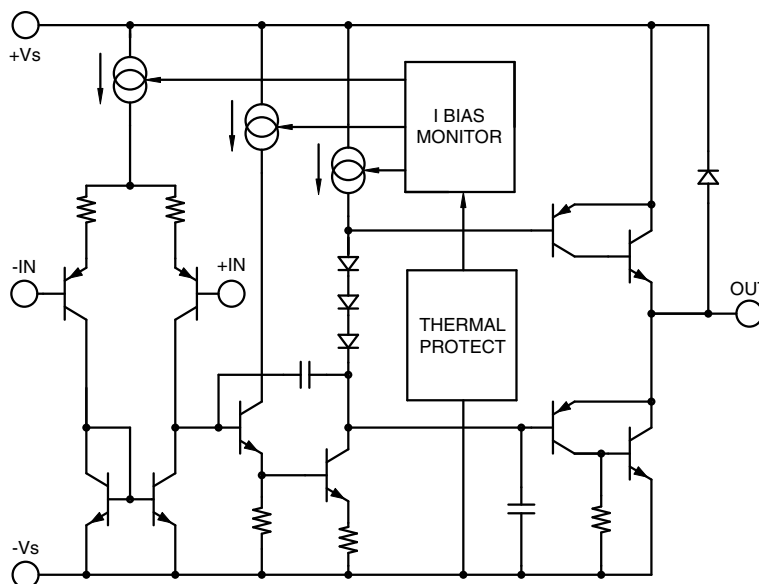

FIGURE 1. Equivalent schematic (one channel)

## 1. CHARACTERISTICS AND SPECIFICATIONS

### ABSOLUTE MAXIMUM RATINGS

Parameter	Symbol	Min	Max	Units
SUPPLY VOLTAGE, total		5	40	V
OUTPUT CURRENT		SOA		
POWER DISSIPATION, internal (1 amplifier)			15	W
POWER DISSIPATION, internal (2 amplifiers) <sup>5</sup>			24	W
POWER DISSIPATION, internal (3 amplifiers) <sup>5</sup>			36	W
POWER DISSIPATION, internal (4 amplifiers) <sup>5</sup>			45	W
INPUT VOLTAGE, differential		-Vs	+Vs	
INPUT VOLTAGE, common mode		+Vs	-Vs-.5V	
JUNCTION TEMPERATURE, max <sup>2</sup>			150	°C
TEMPERATURE, pin solder - 10 secs max.			220	°C
TEMP RANGE STORAGE		-55	150	°C
OPERATING TEMP RANGE, case <sup>2</sup>		-40	125	°C

### SPECIFICATIONS (PER AMPLIFIER)

Parameter	Test Conditions <sup>2,3</sup>	Min	Typ	Max	Units
<b>INPUT</b>					
OFFSET VOLTAGE, initial			1	15	mV
OFFSET VOLTAGE, vs. temperature	Full temp range		20		μV/°C
BIAS CURRENT, initial			100	500	nA
COMMON MODE RANGE	Full temp range	-Vs		+Vs	V
COMMON MODE REJECTION, DC		60	90		dB
POWER SUPPLY REJECTION	Full temp range	60	90		dB
CHANNEL SEPARATION	$I_{OUT} = 500mA, f = 1kHz$	50	68		dB
INPUT NOISE VOLTAGE	$R_s = 100\Omega, f = 1 \text{ to } 100kHz$		22		nV/√Hz
<b>GAIN</b>					
OPEN LOOP GAIN	$V_o = \pm 10V, R_L = 2.0K\Omega$	89	100		dB
GAIN BANDWIDTH PRODUCT	$f = 100kHz, C_L = 100pF, R_L = 2.0K\Omega$		0.9	1.4	MHz
PHASE MARGIN	Full temp range		65		°C
POWER BANDWIDTH	$V_o(P-P) = 28V$		13.6		kHz
<b>OUTPUT</b>					
CURRENT, peak				1.5	A
CURRENT, continuous				1	A
SLEW RATE		1.0	1.4		V/μS
VOLTAGE SWING	Full temp range, $I_o = 100mA$	Vs  -1.1	Vs  -0.8		V
VOLTAGE SWING	Full temp range, $I_o = 1A$	Vs  -1.8	Vs  -1.4		V
HARMONIC DISTORTION	$A_V = 1, R_L = 50\Omega, V_o = .5VRMS, f = 1kHz$		.02		%

Parameter	Test Conditions <sup>2,3</sup>	Min	Typ	Max	Units
<b>POWER SUPPLY</b>					
VOLTAGE, $V_{SS}$ <sup>4</sup>		5	30	40	V
CURRENT, quiescent +Vs (A/B)			8	10	mA
CURRENT, quiescent +Vs (C/D)			8	10	mA
CURRENT, quiescent total			16	20	mA
<b>THERMAL</b>					
RESISTANCE, junction to case					
DC, 1 amplifier			7.16	7.87	°C/W
DC, 2 amplifiers <sup>5</sup>			4.69	5.16	°C/W
DC, 3 amplifiers <sup>5</sup>			3.08	3.39	°C/W
DC, 4 amplifiers <sup>5</sup>			2.51	2.77	°C/W
AC, 1 amplifier			5.37	5.90	°C/W
AC, 2 amplifiers <sup>5</sup>			3.52	3.87	°C/W
AC, 3 amplifiers <sup>5</sup>			2.31	2.54	°C/W
AC, 4 amplifiers <sup>5</sup>			1.89	2.07	°C/W
RESISTANCE, junction to air <sup>7</sup>			25		°C/W

**NOTES:**

1. (All Min/Max characteristics and specifications are guaranteed over the Specified Operating Conditions. Typical performance characteristics and specifications are derived from measurements taken at typical supply voltages and  $T_c = 25^\circ\text{C}$ ).
2. Long term operation at the maximum junction temperature will result in reduced product life. Derate power dissipation to achieve high MTTF.
3. Unless otherwise noted, the following conditions apply:  $\pm V_s = \pm 15\text{V}$ ,  $T_c = 25^\circ\text{C}$ .
4.  $+V_s$  and  $-V_s$  denote the positive and negative rail respectively.  $V_{SS}$  denotes total rail-to-rail supply.
5. Rating applies when power dissipation is equal in each of the amplifiers. Power and thermal ratings are based on two separate dual monolithic power op-amps on one integrated copper heatslug. Amplifiers A and B are combined on one monolithic die while amplifiers C and D are on the other.
6. If  $-V_s$  is disconnected before  $+V_s$ , a diode between  $-V_s$  and ground is recommended to avoid damage.
7. Rating applies when the heatslug of the DK package is soldered to a minimum of 1 square inch foil area of a printed circuit board.

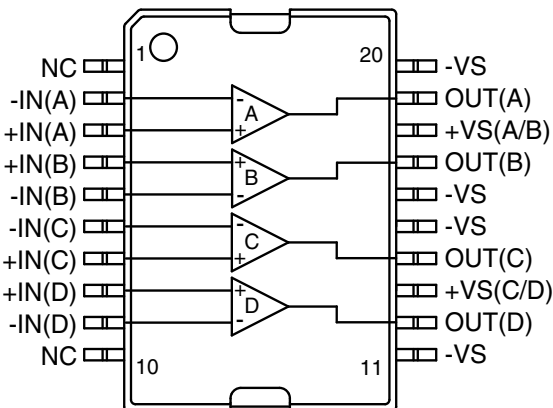

**20-pin PSOP  
PACKAGE STYLE DK**

**FIGURE 2. EXTERNAL CONNECTIONS.**

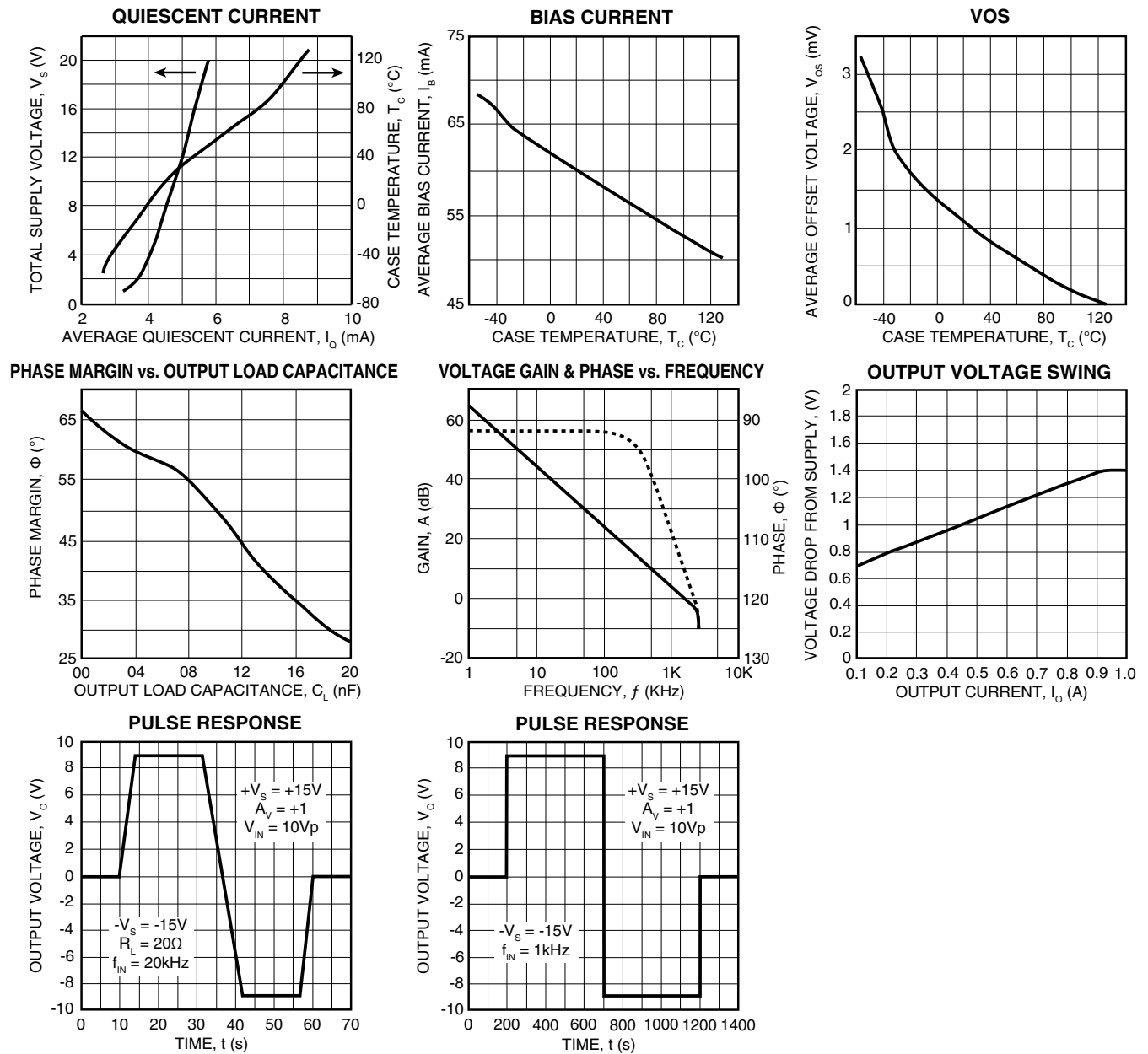

**TYPICAL APPLICATION**

R1 and R2 set up Amplifier A as non-inverting. Amplifier B is set up as a unity gain inverter driven from the output of Amplifier A. Note that Amplifier B inverts the signals about the reference node, which is set at mid-supply by R5 and R6. When the command input is midrange, so is the output of Amplifier A. Since this is also equivalent to the reference node voltage, the output of Amplifier B is the same resulting in 0V across the motor. Inputs more positive than 5V result in motor current flow from left to right (see Figure 3). Inputs less than 5V drive the motor in the opposite direction.

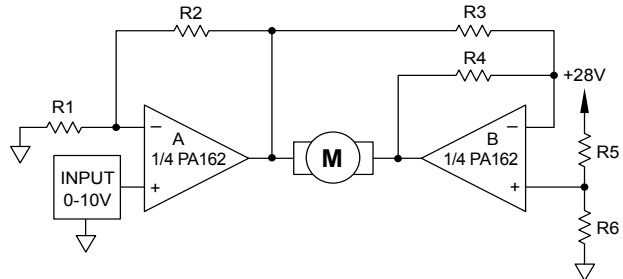

**FIGURE 3. BI-DIRECTIONAL SPEED CONTROL FROM A SINGLE SUPPLY.**

### TYPICAL APPLICATION (CONT)

The amplifiers are especially well-suited for applications such as this. The extended common mode range allows command inputs as low as 0V. The output swing lets it drive within 2V of the supply at an output of 1A. This means that a command input that ranges from 0 to 10V will drive a 24V motor from full scale CCW to full scale CW at  $\pm 1A$ .

$-V_s$  (pins 11, 15, 16 and 20) must be tied to the heatslug externally on the PCB. To ease metal routing on the PCB, run a direct trace from the  $-V_s$  pin to the center heat slug. The PA162 can be used in a three amplifier configuration for a three phase inverter or motor as shown in Figure 4.

### GENERAL

Please read Application Note 1 "General Operating Considerations" which covers stability, supplies, heatsinking, mounting, SOA interpretation, and specification interpretation. Visit [www.cirrus.com](http://www.cirrus.com) for design tools that help automate tasks such as calculations for stability, internal power dissipation, heatsink selection; Apex Precision Power's complete Application Notes library; Technical Seminar Workbook; and Evaluation Kits.

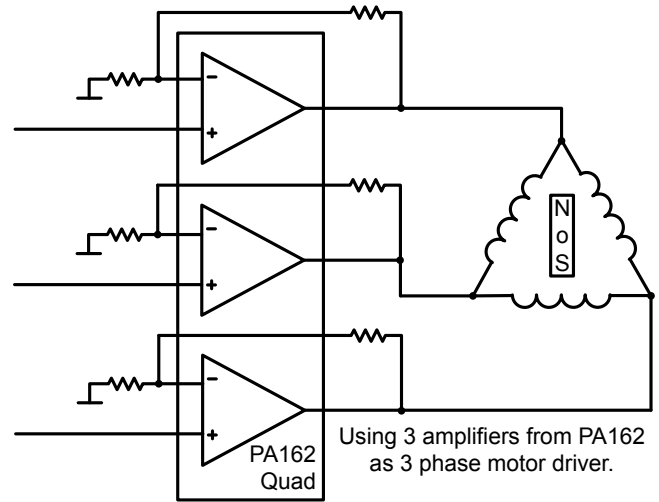

FIGURE 4. 3 Phase Inverter

### STABILITY CONSIDERATIONS

All monolithic power op amps use output stage topologies that present special stability problems. This is primarily due to non-complementary (both devices are NPN) output stages with a mismatch in gain and phase response for different polarities of output current. It is difficult for the op amp manufacturer to optimize compensation for all operating conditions. For applications with load current exceeding 300mA, oscillation may appear. The oscillation may occur only with the output voltage swing at the negative or positive half cycle. Under most operating and load conditions acceptable stability can be achieved by providing a series RC snubber network connected from the output to ground (see Figure 5). The recommended component values of the network are,  $R_{SN} = 10\Omega$  and  $C_{SN} = 0.01\mu F$ . Please refer to Application Note 1 for further details.

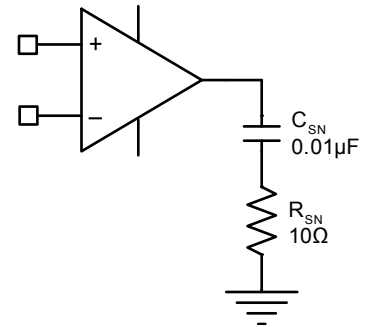
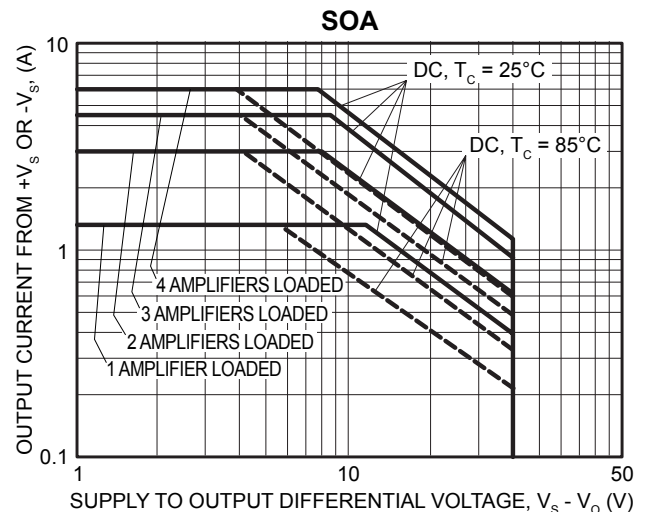

FIGURE 5. R-C Snubber

### SAFE OPERATING AREA (SOA)

The SOA curves combine the effect of all limits for this power op amp. For a given application, the direction and magnitude of the output current should be calculated or measured and checked against the SOA curves. This is simple for resistive loads but more complex for reactive and EMF generating loads. The following guidelines may save extensive analytical efforts.



## THERMAL CONSIDERATIONS

The PA162DK has a large exposed integrated copper heat slug to which the monolithic is directly attached. The solder connection of the heat slug to a minimum of 1 square inch foil area of the printed circuit board will result in thermal performance of 25°C/W junction to air rating of the PA162DK. Solder connection to an area of 1 to 2 square inches of foil is required for minimal power applications.

Where the PA162DK is used in higher power applications, it is necessary to use surface mount techniques of heatsinking. Surface mount techniques include the use of a surface mount fan in combination with a surface mount heatsink on the backside of the FR4/ PC board with through hole thermal vias. Other highly thermal conductive substrate board materials are available for maximum heat sinking.

The Power Derating graph assumes that the power dissipation is equal in each of the amplifiers. Power and thermal ratings are based on two separate dual monolithic power op amps on one integrated copper heat slug. Amps A and B are combined on one monolithic die while amps C and D are combined on the other. This multi chip configuration provides superior thermal performance by isolating each of the dual amplifiers. When loading either of the dual amplifiers it is possible to achieve better thermal performance by loading any combination of amplifiers (A or B) + (C or D).

## MOUNTING PRECAUTIONS

1. Always use a heat sink. Even unloaded the PA162DK can dissipate up to .8 watts.
2. Avoid bending the leads. Such action can lead to internal damage.

POWER DERATING

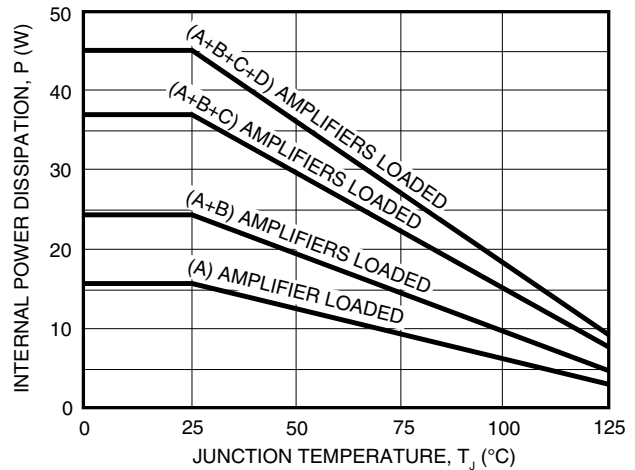

## CONTACTING CIRRUS LOGIC SUPPORT

For all Apex Precision Power product questions and inquiries, call toll free 800-546-2739 in North America.

For inquiries via email, please contact [tucson.support@cirrus.com](mailto:tucson.support@cirrus.com).

International customers can also request support by contacting their local Cirrus Logic Sales Representative.

To find the one nearest to you, go to [www.cirrus.com](http://www.cirrus.com)

### IMPORTANT NOTICE

Cirrus Logic, Inc. and its subsidiaries ("Cirrus") believe that the information contained in this document is accurate and reliable. However, the information is subject to change without notice and is provided "AS IS" without warranty of any kind (express or implied). Customers are advised to obtain the latest version of relevant information to verify, before placing orders, that information being relied on is current and complete. All products are sold subject to the terms and conditions of sale supplied at the time of order acknowledgment, including those pertaining to warranty, indemnification, and limitation of liability. No responsibility is assumed by Cirrus for the use of this information, including use of this information as the basis for manufacture or sale of any items, or for infringement of patents or other rights of third parties. This document is the property of Cirrus and by furnishing this information, Cirrus grants no license, express or implied under any patents, mask work rights, copyrights, trademarks, trade secrets or other intellectual property rights. Cirrus owns the copyrights associated with the information contained herein and gives consent for copies to be made of the information only for use within your organization with respect to Cirrus integrated circuits or other products of Cirrus. This consent does not extend to other copying such as copying for general distribution, advertising or promotional purposes, or for creating any work for resale.

CERTAIN APPLICATIONS USING SEMICONDUCTOR PRODUCTS MAY INVOLVE POTENTIAL RISKS OF DEATH, PERSONAL INJURY, OR SEVERE PROPERTY OR ENVIRONMENTAL DAMAGE ("CRITICAL APPLICATIONS"). CIRRUS PRODUCTS ARE NOT DESIGNED, AUTHORIZED OR WARRANTED TO BE SUITABLE FOR USE IN PRODUCTS SURGICALLY IMPLANTED INTO THE BODY, AUTOMOTIVE SAFETY OR SECURITY DEVICES, LIFE SUPPORT PRODUCTS OR OTHER CRITICAL APPLICATIONS. INCLUSION OF CIRRUS PRODUCTS IN SUCH APPLICATIONS IS UNDERSTOOD TO BE FULLY AT THE CUSTOMER'S RISK AND CIRRUS DISCLAIMS AND MAKES NO WARRANTY, EXPRESS, STATUTORY OR IMPLIED, INCLUDING THE IMPLIED WARRANTIES OF MERCHANTABILITY AND FITNESS FOR PARTICULAR PURPOSE, WITH REGARD TO ANY CIRRUS PRODUCT THAT IS USED IN SUCH A MANNER. IF THE CUSTOMER OR CUSTOMER'S CUSTOMER USES OR PERMITS THE USE OF CIRRUS PRODUCTS IN CRITICAL APPLICATIONS, CUSTOMER AGREES, BY SUCH USE, TO FULLY INDEMNIFY CIRRUS, ITS OFFICERS, DIRECTORS, EMPLOYEES, DISTRIBUTORS AND OTHER AGENTS FROM ANY AND ALL LIABILITY, INCLUDING ATTORNEYS' FEES AND COSTS, THAT MAY RESULT FROM OR ARISE IN CONNECTION WITH THESE USES.

Cirrus Logic, Cirrus, and the Cirrus Logic logo designs, Apex Precision Power, Apex and the Apex Precision Power logo designs are trademarks of Cirrus Logic, Inc. All other brand and product names in this document may be trademarks or service marks of their respective owners.