

Power Booster Evaluation Kit

INTRODUCTION

This easy-to-use kit provides a platform for the evaluation of the PB51 high voltage power boosters. The PB51 is designed most commonly in combination with a small signal, general purpose op amp. However, they can also be used without a driver amplifier. This kit can be used to analyze a multitude of standard or proprietary circuit configurations.

CAUTION

Use the supplied thermal washers or thermal grease between the power amplifier and the heat sink.

PARTS LIST

Part #	Description	Quantity
HS20	Heatsink	1
EVAL30	PC Board	1
MS06	Mating Socket	1
TW07	Thermal Washer	1 package

BEFORE YOU GET STARTED

- All Apex Precision Power amplifiers should be handled using proper ESD precautions.
- Always use the heat sink and thermal washers included in this kit.
- Always use adequate power supply bypassing.
- Do not change connections while the circuit is powered.
- Initially set all power supplies to the minimum operating levels allowed in the device data sheet.
- Check for oscillations.

EQUIVALENT SCHEMATIC

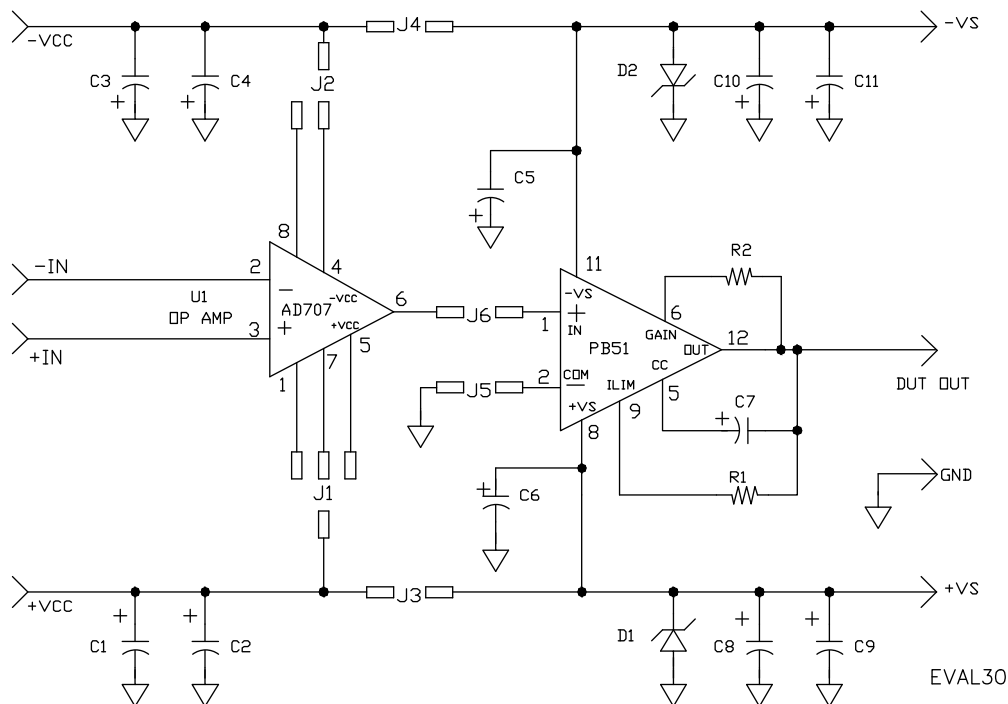

ASSEMBLY

1. On the silk screen side of the evaluation board, insert and solder the MS06 mating socket in DUT holes 1-12. Be sure each one is fully seated.
2. Solder components for your circuit. Be sure to include proper bypassing, required compensation components and current limit resistors. See the op amp data sheet for help in selecting these components.
3. Place the TW07 thermal washer on the heat sink over the mounting hole for the DUT. Place a #6 screw through the mounting hole and thread a #6 nut onto the screw at the back of the heat sink. Do not tighten. Note that there are two sets of mounting holes on the HS20. Holes on one edge allow room between the DUT and evaluation board for the MS06 socket. The holes on the other edge are for direct through hole mounting of the DUT to the evaluation board. It is recommended that you use the MS06.
4. Mount the DUT to the HS20 by sliding under the head of the #6 screw and on top of the thermal washer. Tighten the nut to the specified 8 to 10 in-lbs. (.9 to .13 N*M) do not over torque.
5. Install leads of the DUT into the the MS06 on the evaluation board. Use #6 self-tapping screws to secure the evaluation board to the HS20 heatsink as shown in the assembly diagram (Figure1).

FIGURE 1.

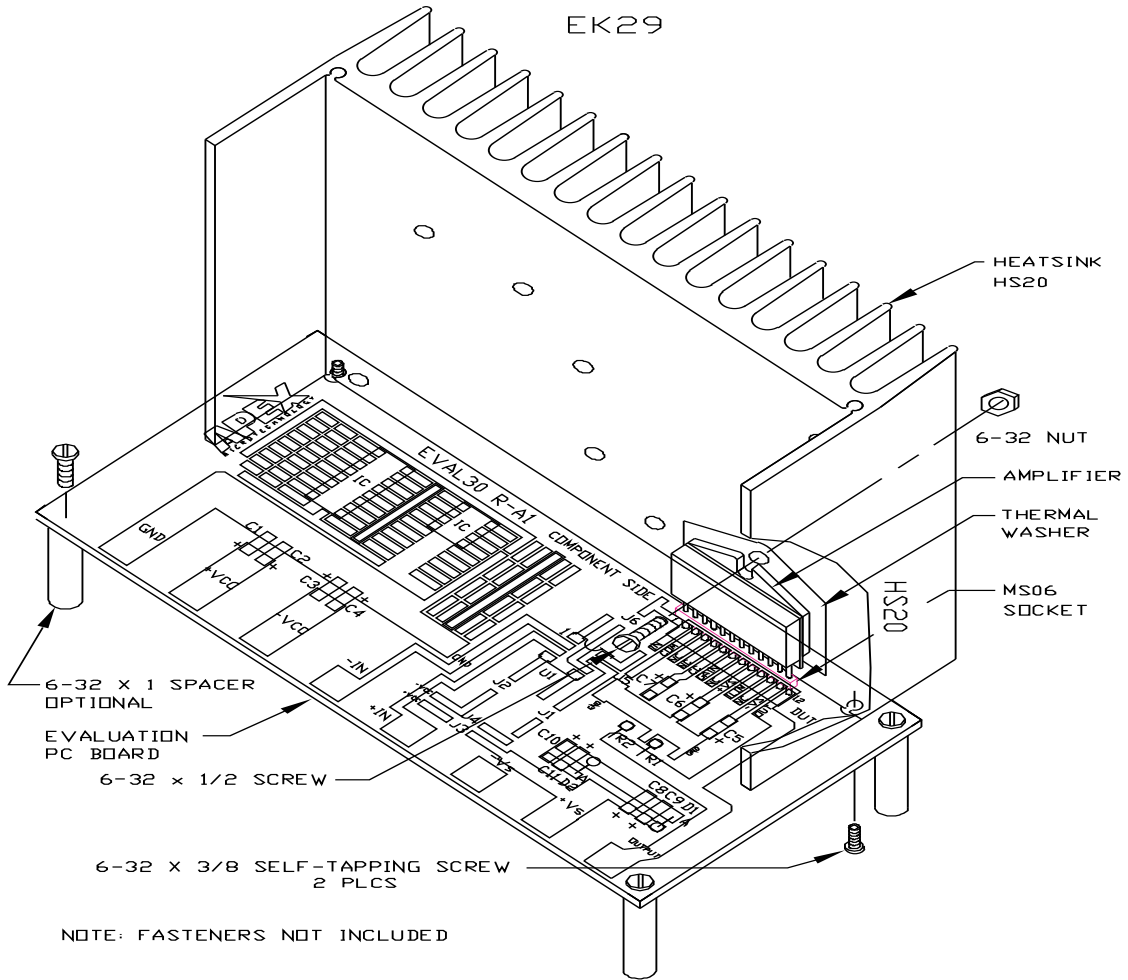
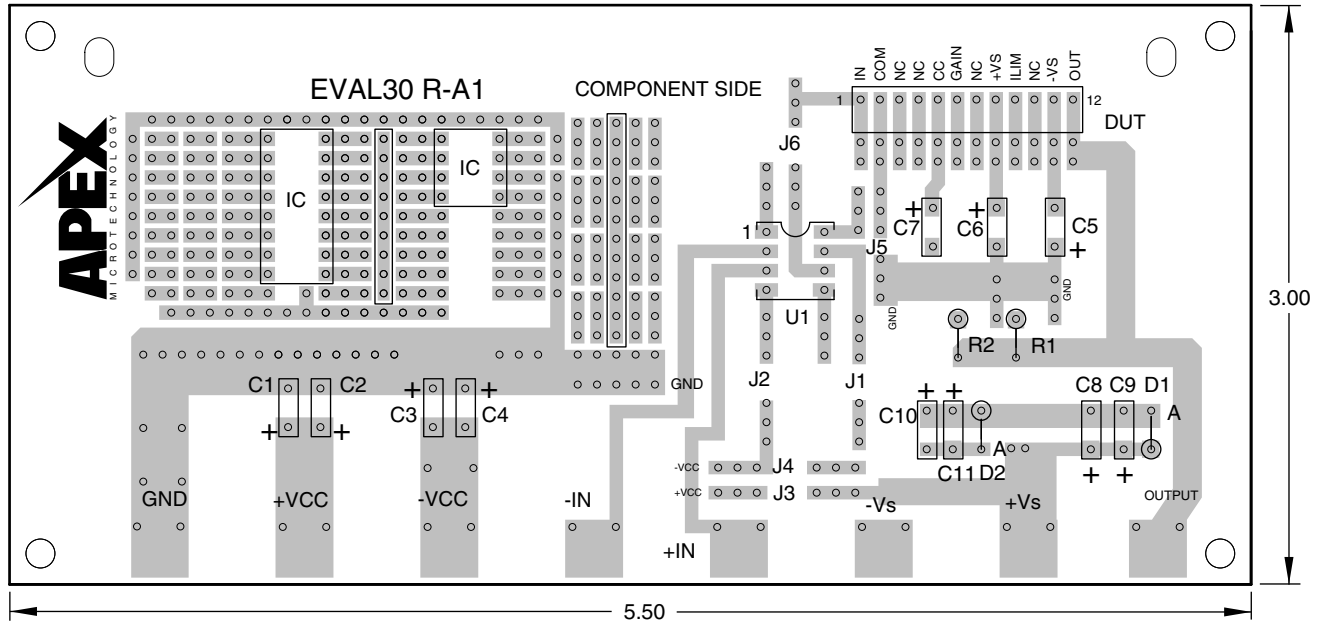
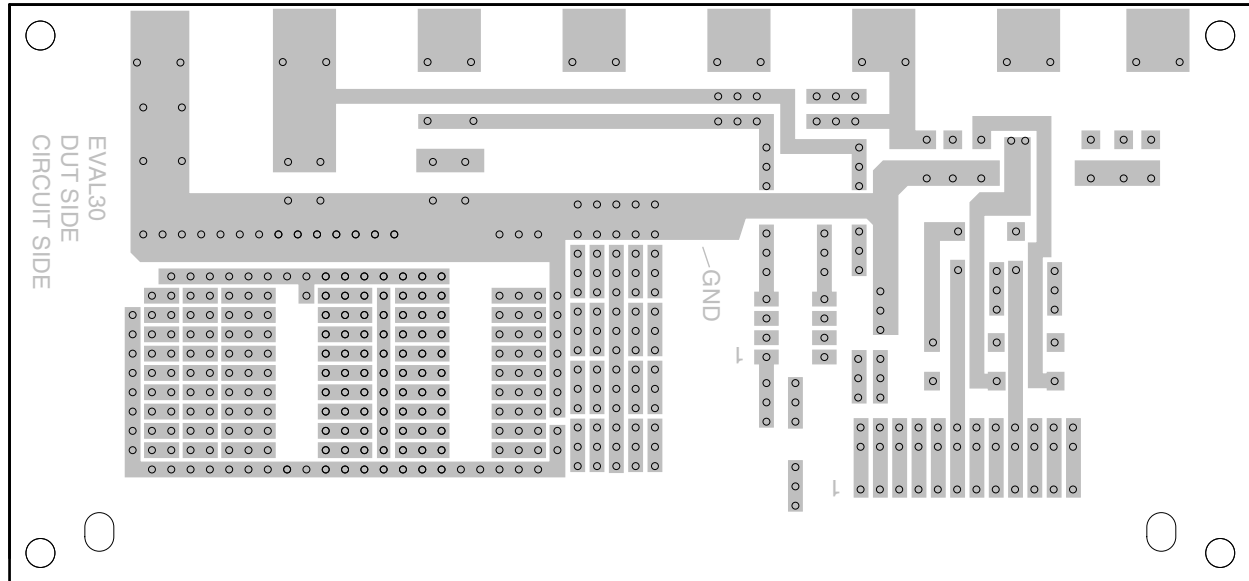

FIGURE 3. PCB

TOP SIDE



BOTTOM SIDE



CONTACTING CIRRUS LOGIC SUPPORT

For all Apex Precision Power product questions and inquiries, call toll free 800-546-2739 in North America.

For inquiries via email, please contact apex.support@cirrus.com.

International customers can also request support by contacting their local Cirrus Logic Sales Representative.

To find the one nearest to you, go to www.cirrus.com

IMPORTANT NOTICE

Cirrus Logic, Inc. and its subsidiaries ("Cirrus") believe that the information contained in this document is accurate and reliable. However, the information is subject to change without notice and is provided "AS IS" without warranty of any kind (express or implied). Customers are advised to obtain the latest version of relevant information to verify, before placing orders, that information being relied on is current and complete. All products are sold subject to the terms and conditions of sale supplied at the time of order acknowledgment, including those pertaining to warranty, indemnification, and limitation of liability. No responsibility is assumed by Cirrus for the use of this information, including use of this information as the basis for manufacture or sale of any items, or for infringement of patents or other rights of third parties. This document is the property of Cirrus and by furnishing this information, Cirrus grants no license, express or implied under any patents, mask work rights, copyrights, trademarks, trade secrets or other intellectual property rights. Cirrus owns the copyrights associated with the information contained herein and gives consent for copies to be made of the information only for use within your organization with respect to Cirrus integrated circuits or other products of Cirrus. This consent does not extend to other copying such as copying for general distribution, advertising or promotional purposes, or for creating any work for resale.

CERTAIN APPLICATIONS USING SEMICONDUCTOR PRODUCTS MAY INVOLVE POTENTIAL RISKS OF DEATH, PERSONAL INJURY, OR SEVERE PROPERTY OR ENVIRONMENTAL DAMAGE ("CRITICAL APPLICATIONS"). CIRRUS PRODUCTS ARE NOT DESIGNED, AUTHORIZED OR WARRANTED TO BE SUITABLE FOR USE IN PRODUCTS SURGICALLY IMPLANTED INTO THE BODY, AUTOMOTIVE SAFETY OR SECURITY DEVICES, LIFE SUPPORT PRODUCTS OR OTHER CRITICAL APPLICATIONS. INCLUSION OF CIRRUS PRODUCTS IN SUCH APPLICATIONS IS UNDERSTOOD TO BE FULLY AT THE CUSTOMER'S RISK AND CIRRUS DISCLAIMS AND MAKES NO WARRANTY, EXPRESS, STATUTORY OR IMPLIED, INCLUDING THE IMPLIED WARRANTIES OF MERCHANTABILITY AND FITNESS FOR PARTICULAR PURPOSE, WITH REGARD TO ANY CIRRUS PRODUCT THAT IS USED IN SUCH A MANNER. IF THE CUSTOMER OR CUSTOMER'S CUSTOMER USES OR PERMITS THE USE OF CIRRUS PRODUCTS IN CRITICAL APPLICATIONS, CUSTOMER AGREES, BY SUCH USE, TO FULLY INDEMNIFY CIRRUS, ITS OFFICERS, DIRECTORS, EMPLOYEES, DISTRIBUTORS AND OTHER AGENTS FROM ANY AND ALL LIABILITY, INCLUDING ATTORNEYS' FEES AND COSTS, THAT MAY RESULT FROM OR ARISE IN CONNECTION WITH THESE USES.

Cirrus Logic, Cirrus, and the Cirrus Logic logo designs, Apex Precision Power, Apex and the Apex Precision Power logo designs are trademarks of Cirrus Logic, Inc. All other brand and product names in this document may be trademarks or service marks of their respective owners.
